

# ROBINAIR®

AN SPX BRAND



## High Performance Vacuum Pump

Model 15401/15601/15603/15605/15607

Operating Manual ..... 2

## Bombas de Vacío de Alto Rendimiento

Modelo 15401/15601/15603

Manuel del Operador ..... 8

## Pompe à Vide à Haut Rendement

Modèle 15401/15601/15603

Manuel d'utilisation ..... 16

## Hochleistungs-Vakuumpumpe

Modelle 15401/15601/15603

Bedienungsanleitung ..... 24

## Table of contents

.....

CoolTech® high performance vacuum pumps ..... 2

Pump components..... 3

Warnings ..... 3

Before using your vacuum pump..... 4

To use the gas ballast feature..... 5

To shut down your pump after use ..... 5

To maintain your high vacuum pump..... 5

    Vacuum pump oil ..... 5

    Oil change procedure ..... 5

    Cleaning your pump..... 5

    Motor lubrication ..... 5

Troubleshooting guide ..... 6

Failure to start..... 6

    Oil leakage..... 6

    Failure to pull a good vacuum..... 6

CoolTech® pump specifications ..... 6

Replacement parts ..... 7

Warranty coverage ..... 7

    Out of warranty ..... 7

**For use on A/C-R systems using CFCs, HCFCs and HFCs in conjunction with mineral oil, ester oil, alkylbenzene oil and PAG oil as lubricants. Not for use with ammonia or lithium bromide systems. Not for use with flammable refrigerants.**

## CoolTech® high performance vacuum pumps

.....

Congratulations on purchasing one of Robinair's top quality CoolTech® vacuum pumps. Your pump has been engineered specifically for air conditioning and refrigeration service, and is built with Robinair's proven offset rotary vane for fast, thorough evacuation.

You'll appreciate these key features . . .

### **Iso-Valve™**

Allows the pump to be shut off while still connected to the A/C-R system, which is handy for checking rate of rise. With the valve handle in the OPEN position, the pump is open to the system being evacuated. In the CLOSE position, the pump is isolated from the system. This minimizes pump oil pulled into the pumping module, making start-up easier and reducing wear and tear on the pump components.

### **High vacuum rating**

The two-stage, offset rotary vane design provides powerful, quiet, high vacuum capability and ensures moisture removal, while the high pumping capacity reduces evacuation time.

### **Lifetime filtration**

The intake filter prevents foreign matter from entering the pumping chamber, and an internal exhaust filter separates oil vapor from the exhaust flow.

### **Directed exhaust**

The exhaust is expelled through the handle to direct it away from the service technician.

### **Gas ballast**

A precise amount of atmospheric air is introduced into the pump, preventing condensation of moisture vapor and helping maintain the purity of the pump oil. By using the gas ballast, the pump operates more efficiently and pump life is extended.

### **Sure-grip handle**

The one-piece, molded handle makes it easy to carry the pump to and from job sites, and the handle stays cool to the touch during operation.

### **Compact design**

The pump measures approximately 40 cm long, while aluminum housing and offset rotary vanes keep the pump weight low, making it easy to carry.

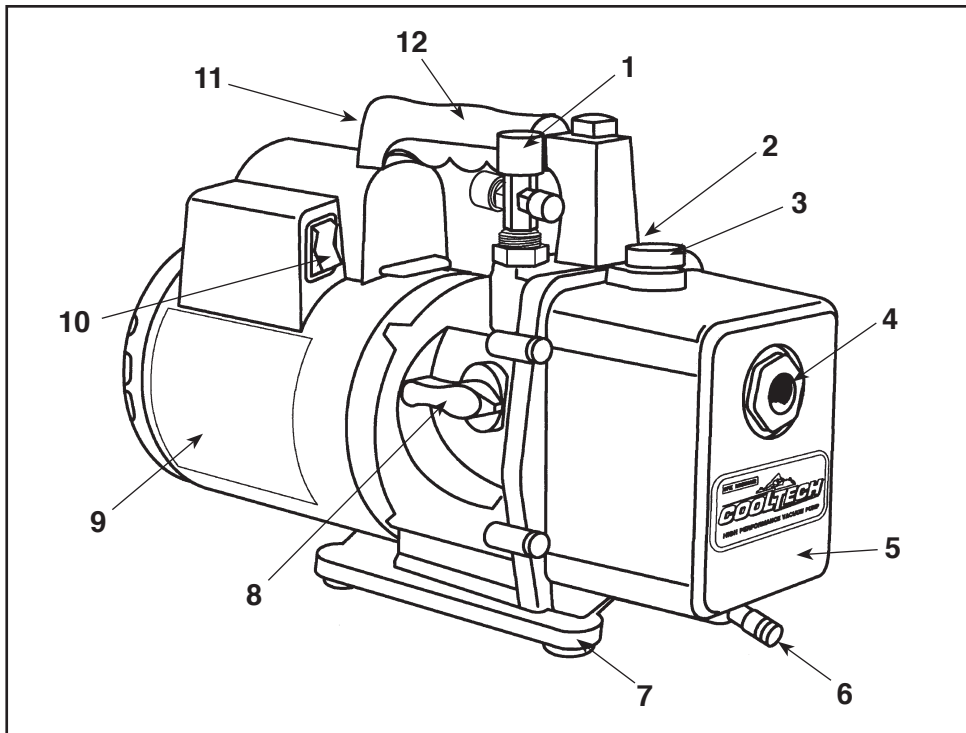

### Pump Components

1. Intake Fitting
2. Gas Ballast Valve  
(located beside handle base)
3. Oil Fill Port
4. Sight Glass
5. Die-Cast Aluminum Housing
6. Oil Drain
7. Molded Polycarbonate Base
8. Iso-Valve™  
(isolates the pump from the system)
9. High Torque Motor
10. Power Switch
11. Through-the-Handle Exhaust
12. Sure-Grip Handle

### Warnings



Wear goggles when working with refrigerants. Contact with refrigerants may cause injury.



Incorrect use or connections may cause electrical shock. Study and follow the instructions carefully, and take precautions to avoid electrical shock hazards. All associated devices must be grounded before energizing circuits.



The normal operating temperature will cause certain external portions of the pump to be hot to the touch. Do not touch the pump housing or motor during operation.

## NOTICE: Airborne Noise Emissions

**This equipment has been tested for airborne noise emission per the Council Directive for Machinery (89/392/EEC) Section 1.7.4 Instructions – Essential Health and Safety Requirements. Sound levels do not exceed 80dB(A) actual value.**

## Before using your vacuum pump

In all cases, motors are designed for operating voltages plus or minus 10% of the normal rating (see SPECIFICATIONS).

1. Verify the voltage and frequency at the outlet match the specifications on the pump motor decal. Verify the ON / OFF switch is in the OFF position before you plug the pump into an outlet. Verify the gas ballast valve is closed. Remove and discard the exhaust plug from the end of the pump's handle.
2. The pump is shipped without oil in the reservoir. Before starting the pump, fill with oil. Remove the OIL FILL cap (black plastic plug directly in front of the handle), and add oil until the oil just shows in the bottom of the sight glass. The approximate oil capacity of the pump is 375 milliliters.
3. Replace the OIL FILL cap and remove the cap from one of the inlet ports. Turn the Iso-Valve to OPEN. Turn the motor switch ON. When the pump runs smoothly, turn the Iso-Valve to CLOSED and replace the cap on the inlet port. This may take from two to 30 seconds, depending on the ambient temperature. After the pump runs for approximately one minute, check the sight glass for correct oil level — oil should be even with the sight glass OIL LEVEL line. Add more oil if necessary.

When the pump is running, the oil level should be even with the line on the sight glass. Underfilling will result in poor vacuum performance. Overfilling can result in oil blowing from the exhaust.

Your pump is now ready to evacuate air conditioning and refrigeration systems. Follow normal service procedures and the A/C-R manufacturer's instructions for connections to the system.

**CAUTION!** Before connecting the vacuum pump to an A/C-R system, remove refrigerant from the system in an accepted manner. Damage to the pump may occur if evacuation is started while the system is under high pressure. Robinair recommends use of our Refrigerant Recovery and Recycling equipment.

### Wiring Instructions:

The CoolTech vacuum pump features dual voltage ranges. Before operating the pump, read and follow these rewiring instructions (if necessary) to be sure your pump is wired for the appropriate voltage.

**CAUTION!** Unplug the unit before beginning any service work. Incorrect use or connections can cause electrical shock. Only qualified personnel should perform service work.

The CoolTech vacuum pump is factory wired for a high voltage range of 220 to 250 volts. To wire the switch for a low voltage range of 110 volts to 115 volts, follow these steps:

1. Disconnect the unit from the AC power source.
2. Loosen the screws on the plate at the rear of the motor, and carefully move the plate aside to clear the opening.
3. Disconnect the leads and reconnect for low voltage, following the diagram and chart. (High voltage connections are also shown if you want to rewire in the future.)
4. Verify connections are secure and there are no short circuits. Verify the grounding connector is correctly connected.
5. Re-install the plate on the rear of motor with the screws which were loosened in Step 2.

**IMPORTANT:** Check for short circuits using a continuity tester before reconnecting to the AC power source.

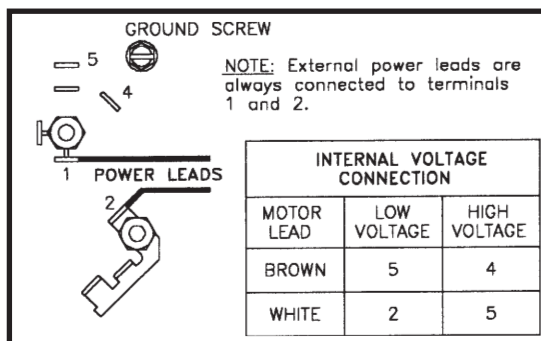

General Electric Motors

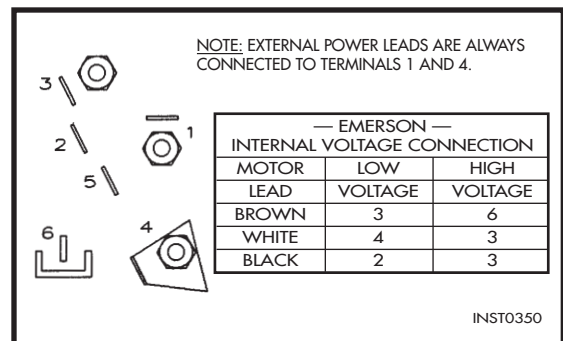

Emerson Motors

## To use the gas ballast feature

Moisture from the A/C-R system that is carried into the pump as a vapor tends to condense into a liquid and combine with the vacuum pump oil. When moisture contaminates the pump oil, it reduces the pump's ability to reach its ultimate deep vacuum level.

The gas ballast valve purges a small amount of atmospheric air through the exhaust chamber. This extra volume of air mixes with the vapor from the refrigerant system to prevent condensation and to help exhaust moisture in the form of vapor from the pump.

To use the gas ballast, start the pump and open the gas ballast valve until the system has reached approximately 1000-3000 microns. Close the valve to allow the pump to pull down to its ultimate vacuum level. (The gas ballast valve is located beside the handle, opposite the inlet fitting.)

The gas ballast valve may be opened or closed at any time during pump operation. It is fully open at two turns counterclockwise.

*NOTE: Robinair recommends the use of a thermistor vacuum gauge to most accurately measure vacuum levels.*

## To shut down the pump after use

To help prolong pump life and promote easy starting, follow these procedures for shutdown:

1. Close the manifold valve between the pump and the system.
2. Turn the Iso-Valve to the CLOSED position.
3. Remove the hose from the pump inlet.
4. Turn the pump power switch to OFF, then return the Iso-Valve to the OPEN position for a few seconds to relieve any vacuum inside the pump.
5. Cap the inlet port to prevent any contamination or loose particles from entering the port.

## To maintain the high vacuum pump

For maximum performance, Robinair recommends changing vacuum pump oil after each use.

### Vacuum pump oil

The condition and type of oil used in any high vacuum pump are extremely important in determining the ultimate attainable vacuum. Robinair recommends the use of our Premium High Vacuum Pump Oil. This oil has been specifically blended to maintain maximum viscosity at normal running temperatures and to improve cold weather starts.

Our Premium High Vacuum Pump Oil is available in quart or gallon containers. Order by part number:

- 13203 — Quart (shipped 12 quarts per case)
- 13204 — Gallon (shipped 4 gallons per case)

### Oil change procedure

1. Be sure the pump is warmed up.
2. Remove the OIL DRAIN cap. Drain contaminated oil into a suitable container and dispose of correctly. Oil can be forced from the pump by opening the inlet and partially blocking the exhaust with a cloth while the pump is running. Do not operate the pump for more than 20 seconds using this method.
3. When the flow of oil has stopped, tilt the pump forward to drain residual oil.
4. Replace the OIL DRAIN cap. Remove the OIL FILL cap, and fill the reservoir with new vacuum pump oil until the oil just shows at the bottom of the sight glass. The approximate oil capacity of the pump is 375 milliliters.
5. Verify the inlet ports are capped. Turn ON the pump, and allow it to run for one minute. Check the oil level. If the oil is below the sight glass OIL LEVEL line, add oil slowly (with the pump running) until the oil reaches the OIL LEVEL line. Replace the OIL FILL cap, cap the inlet, and tighten the drain cap.
6. If the oil is badly contaminated, you may need to flush the pump. To flush, remove the pump drain cap and start the pump. Slowly pour a small quantity of new pump oil through the oil fill inlet.

Repeat this procedure as required until the contamination is removed. Replace the OIL DRAIN cap and refill the reservoir to the correct level using fresh pump oil (Step 4).

### Cleaning the pump

Use only soap and water to clean the pump. Do not use commercial cleaners that contain degreasing agents that can damage polycarbonates. The pump handle and base are made of Lexan, one of the toughest polycarbonate plastics available. However, it is sensitive to degreasing agents.

*\*Lexan is a registered trademark of General Electric*

### Motor lubrication

After three years of normal service or one year of heavy-duty service, add motor oil. Use electric motor oil or SAE 10 oil.

## Troubleshooting guide

This CoolTech pump has been designed for dependable use and long life. If something should go wrong, however, the following guide will help you get the pump back into service as quickly as possible.

If disassembly of the pump is required, please check your warranty. The warranty may be voided by misuse or customer tampering that results in the pump being inoperable.

### Failure to start

Check line voltage. Robinair pumps are designed to start at  $\pm 10\%$  line voltage (loaded) at 0°C. At extremes, however, switching between the start and run windings may occur. When starting the pump in cold temperatures, verify the Iso-Valve and inlet port are open to free air.

### Oil leakage

1. Verify the oil is not a residual accumulation from spillage, etc.
2. If leakage exists, the module cover gasket or the shaft seal may need replacing. Follow the instructions supplied with the seal replacement kit, part number 15367. If leakage exists in the area of the drain plug, reseal the plug using a commercial pipe thread sealer.

### Failure to pull a good vacuum

1. Verify the Iso-Valve on the pump is in the OPEN position, and the gas ballast knob is tightly sealed.
2. Verify the vacuum gauge and all connections are in good condition and leak-free. Confirm leakage by monitoring the vacuum with a thermistor gauge while applying vacuum pump oil at connections or suspected leak points. Vacuum will improve briefly while the oil is sealing the leak.
3. Be sure the pump oil is clean. A badly contaminated pump may require several oil flushes. See OIL CHANGE PROCEDURE.
4. Verify the oil is at the correct level. For maximum pump operation, the oil must be even with the OIL LEVEL line on the sight glass when the pump is running. See OIL CHANGE PROCEDURE. Do not overfill. Operating temperatures cause the oil to expand, so it will appear at a higher level than when the pump is not running. To check the oil level, start the pump with the inlet capped. Check the oil level in the sight glass. Add oil if necessary.

U.S. Patents 4,523,897; 5,209,653. Other U.S. and Foreign Patents Pending.

## CoolTech® pump specifications

### Model 15401

Frequency Range .....	50-60 Hz
Free Air Displacement .....	4 cfm/60 Hz
.....	94 l/m @ 50 Hz
.....	113 l/m @ 60 Hz
Stages .....	2
Motor Speed .....	1425 rpm @ 50 Hz
.....	1725 rpm @ 60 Hz
Voltage Range .....	110V-115V
.....	220V-250V
Factory Micron Rating .....	15 microns
Approximate Oil Capacity .....	400 ml
Weight .....	15 kg
Width .....	14.29 cm
Height .....	24.6 cm
Length .....	40 cm
Intake .....	1/4" and 1/2" SAE MFL
Min. Starting Temp. (at 90% voltage) .....	0°C
Motor Size .....	0.25kW (1/3 HP) Capacitor Start
Operating Temp. ....	68°C

### Models 15601/15603/15605

Frequency Range .....	50-60 Hz
Free Air Displacement .....	6 cfm/60 Hz
.....	142 l/m @ 50 Hz
.....	170 l/m @ 60 Hz
Stages .....	2
Motor Speed .....	1425 rpm @ 50 Hz
.....	1725 rpm @ 60 Hz
Voltage Range .....	110V-115V
.....	220V-250V
Factory Micron Rating .....	15 microns
Approximate Oil Capacity .....	400 ml
Weight .....	15.2 kg
Width .....	14.29 cm
Height .....	24.6 cm
Length .....	42 cm
Intake .....	1/4", 3/8", and 1/2" SAE MFL
Min. Starting Temp. (at 90% voltage) .....	0°C
Motor Size .....	0.375 kW (1/2 HP) Capacitor Start
Operating Temp. ....	68°C

### Notes:

1. All motors are internally protected (automatic reset).
2. Operating temperatures are typical for normal operating conditions.
3. Model 15603 has a bipolar side grounded plug.
4. Models 15405 & 15605 have Australian plugs.

Because of ongoing product improvements, we reserve the right to change design, specifications, or materials without notice.

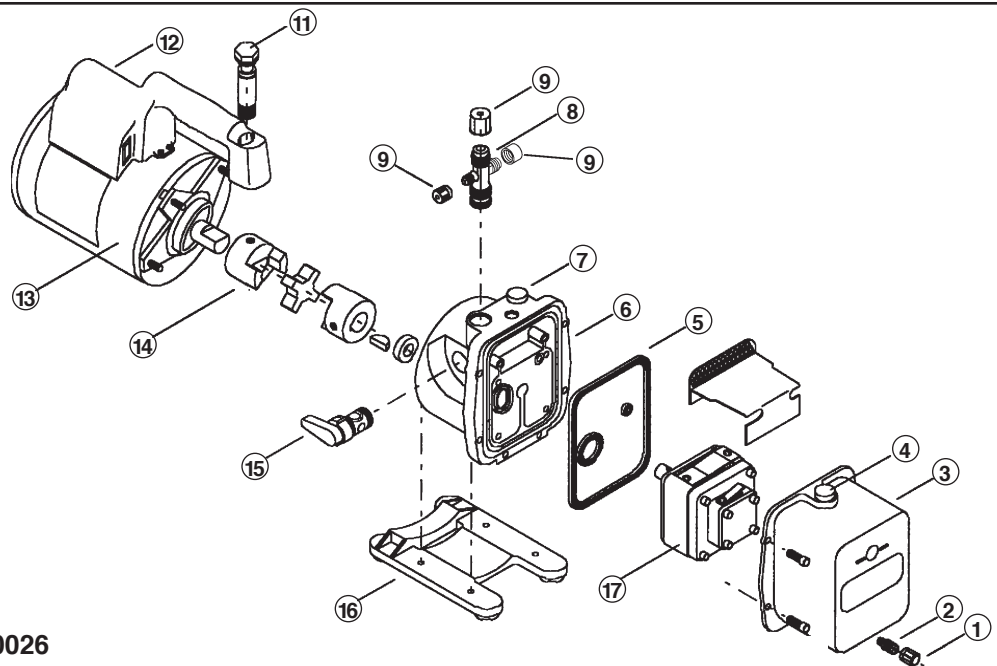

**INST0026**

**Model 15607 Specifications**

Voltage Range	220V
Frequency Range	50 Hz
Free Air Replacement	142 l/m
Stages	2
Motor Speed	1425 rpm
Factory Micron Rating	15 microns
Approximate Oil Capacity	400 ml
Weight	15 kg
Width	14.29 cm
Height	24.6 cm
Length	42 cm
Intake	1/4", 3/8", & 1/2" SAE MFL
Min. Starting Temp. at 90% Voltage	0°C
Motor Size	.37 kW (1/2 hp) Capacitor Start
Operating Temperature	68°C

**Warranty coverage**

Robinair CoolTech® vacuum pumps are warranted against defects in material and workmanship for one year of normal use from the date of purchase. See your distributor for warranty details.

**Out of warranty**

A pump which is no longer covered by the one-year warranty period and which fails to operate properly should be returned to the distributor with a full written explanation of the problem. The distributor may suggest returning the pump to the factory. Before returning an out-of-warranty pump, review all maintenance procedures to avoid an unnecessary return. Replacement parts are available for doing your own service.

**Replacement parts**

Part	Item	15607/ 15605/ 15601/ 15603		Part	Item	15607/ 15605/ 15601/ 15603	
		15401	15603			15401	15603
Oil Drain Cap (6)	1	40572	40572	Vent Bolt (includes o-rings)	11	15338	15338
Oil Drain Kit (includes Item No. 1)	2	13193	13193	Handle, Power Cord and Switch Assembly	12	15466	15466
Module Cover Kit (includes Nos. 2, 4, and 5)	3	15337	15337	Motor	13	15465	15665
Oil Fill Cap (includes No. 7)	4	15371	15371	Coupling	14	13192	13192
Intake Fitting (includes No. 9)	8	15364	555124	Iso-Valve™ Assembly	15	15368	15368
Intake Cap (1 ea.) 1/4", 3/8", 1/2" SAE MFL	9	555133	555133	Base and Foot Assembly	16	15369	15369
				Pump Assembly, less motor (includes No. 3 and 6)	17	15547	15548
				Seal Replacement Kit (not shown)	--	15367	15367



**Call our Toll-Free  
Technical Support Line at**

**800-822-5561**

**in the continental U.S. and Canada**

**or visit our website**

**[www.robinair.com](http://www.robinair.com)**

In all other locations, contact your local distributor. To help us serve you better, be prepared to provide the model number, serial number, and date of purchase of your unit.

To validate your warranty, complete the warranty card attached to your unit and return it within ten days from date of purchase.

**NATIONWIDE NETWORK OF AUTHORIZED SERVICE CENTERS**

If your unit needs repairs or replacement parts, contact the service center in your area. For help in locating a service center, call the toll-free technical support line, or visit our website.

Due to ongoing product improvements, we reserve the right to change design, specifications, and materials without notice.

**ROBINAIR**<sup>®</sup>  
AN SPX BRAND

SPX CORPORATION  
655 EISENHOWER DRIVE  
OWATONNA, MN 55060-0995 USA  
TECHNICAL SERVICES: 1-800-822-5561  
FAX: 1-412-690-2001  
CUSTOMER SERVICE: 1-800-533-6127  
FAX: 1-800-283-8665  
WEB SITE: [WWW.ROBINAIR.COM](http://WWW.ROBINAIR.COM)