

# EndoFlush®

## Internal coil and system cleaner

EndoFlush® is an internal system cleaner ideal for use after a burnout or retrofit. Its low viscosity allows it to be circulated freely around a system to remove contaminants and physical debris, using a flushing pump. On contact, EndoFlush® will break down all carbon, tar, oil and sludge deposits. These contaminants are flushed out of the system, leaving internal surfaces clean and ready for re-commissioning. EndoFlush is CFC-free and is not a regulated substance.

### Specification

Name	EndoFlush
Product Code	ENFL0405
Packing Quantity	4 x 5 litre
Packing Size (L x H x D) cm	40 x 30 x 27
Shipping Weight (Kg)	22
Shipping Volume (m <sup>3</sup> )	0.0324
Application	Internal Coil Cleaner and System Flush
Soils	Sludge, Carbon residues, acids, oils and water
Dilution (water:product)	N/A
Contact Period	As required
Rinse/Flush Required	N/A
Special Features	Non Flammable CFC Free



## Directions for use

### Considerations

- Always ensure remaining refrigerant is recovered in a legal manner.
- It is recommended that systems should be flushed in sections.
- EndoFlush is not a refrigerant and cannot be removed with a vacuum pump.
- While tests show that EndoFlush will not harm materials most commonly found in compressors, it is not intended for use in an operating system.

### Dosage:

- For EndoFlush to clean thoroughly, the system or its components should be fully filled, this will ensure that all internal surfaces are wetted. Therefore in order to determine the amount of EndoFlush required, the user should calculate the internal system volume.
- To ensure thorough removal of EndoFlush, it is advised that the amount of product used and removed is recorded. The difference (i.e. what is left in the system) must not exceed 5% of the oil charge.

**Full step-by-step instructions overleaf...**

### EndoFlush®

**Contains Ethyl Diglycol**

S1/2: Keep locked up and out of the reach of children. S24/25: Avoid contact with skin and eyes. S26: In case of contact with eyes, rinse immediately with plenty of water and seek medical advice. S45: In case of accident or if you feel unwell, seek medical advice immediately (show the label where possible).

Consult Safety Data Sheet for full safety information. Always wear suitable PPE.



**advanced**  
engineering

**Advanced Engineering Ltd**  
Guardian House, Stroudley Road  
Basingstoke, Hants, RG24 8NL, UK  
Tel: +44(0)1256 460300  
sales@advancedengineering.co.uk  
www.advancedengineering.co.uk

## Directions for use

### Before Starting

- Using a refrigerant recovery unit (Promax, MiniMax or similar) remove all the refrigerant from the system and dispose of it in an environmentally acceptable manner as per local legislation.
- Disconnect the compressor, dryer and expansion valve (or capillary line). Solenoid and / or check valves should also be removed or have a bypass fitted. Suction line accumulators, oil separators and liquid receivers should be flushed as individual components, due to their potentially large volumes, so should also be bypassed or removed.
- It is recommended that the Condensing coil, the Evaporating coil and the interconnecting pipe work are flushed as three separate sections.
- Select a suitable pump for your needs – An Advanced Engineering HydroPump is recommended. Keep in mind that your chosen pump needs to be solvent resistant and have sufficient “head” and “flow rate” to achieve a turbulent flow within the pipe work - thus agitating any sludge within the system and aiding its removal. It is also helpful if the pump is “self-priming”.
- Select a suitable tank of a volume in excess of that required to completely fill the largest of the sections to be cleaned.

### Flushing

1. Connect the pump and tank to the condensing coil (for example) as indicated in Fig. 1. If using conventional refrigeration hoses ensure that all the Schrader valves have been removed from the ends of the hoses.
2. Measure into the tank sufficient EndoFlush to fill the condenser, leaving enough additional product in the tank to ensure a flooded pump suction.
3. Start the pump and allow the EndoFlush to circulate for about 10 to 15 minutes. At the start observe the solution returning to the tank from the condenser to monitor contamination pickup.
4. If the system is only slightly contaminated then only one flush may be required. If, however, there is considerable contamination it may be necessary to flush the system a second time with virgin EndoFlush. In the event that a second flush is required, this EndoFlush can be re-used as the first (“dirty”) flush for the next section to be flushed, assuming that it is not too contaminated.
5. Remove the Suction Hose from the supply tank and attach a nitrogen cylinder to the hose. Blow nitrogen through the pump and the system until all EndoFlush has been removed and discharged, via the Return Hose, into the tank, or until what remains in the system in total (NOT each Section) is less than 5% of the system oil charge. EndoFlush cannot be removed from the system using a vacuum pump.
6. The used EndoFlush can be pumped back into the original container by putting the Suction Hose back into the EndoFlush reservoir, disconnecting the Discharge Hose from the system and discharging the product. If a second flush is required then proceed from 2 (above), if not proceed to 7 (below).

7. Repeat steps 1 to 6 for the other parts of the system (Evaporator, Pipe Work, etc). If a capillary is suspected as being blocked it is vital that it is first removed.

8. Remove the Suction Hose from the reservoir and connect the hose to a nitrogen cylinder. Position the Discharge Hose within the reservoir. Allow nitrogen to flow through the pump and thus purge all possible EndoFlush from within the pump into the reservoir. Manually drain EndoFlush from the reservoir into the original container.

9. Reconnect system. Fit new filter drier or cores. As per best practice complete a final system purge with dry nitrogen followed by the normal evacuation procedure.

### After using

- A further filter dryer, or core, change may be necessary once the system is working. It is likely that a small amount of EndoFlush (always less than 5% of the oil charge) will remain within the system and continue to clean any remaining residues. If present in the system these residues will be retained by the filter dryer and should be removed as soon as possible.
- Upon completion ensure that NO EndoFlush remains within the pump, as this may be detrimental to its future use.
- Once used, EndoFlush will probably contain hazardous substances, acids, oil residues and, in the event of a burnout, products of combustion. Used EndoFlush should, therefore, be treated as Hazardous Waste and should be correctly disposed of by a specialist waste contractor. Advanced Engineering Ltd offer a chargeable disposal service if required.

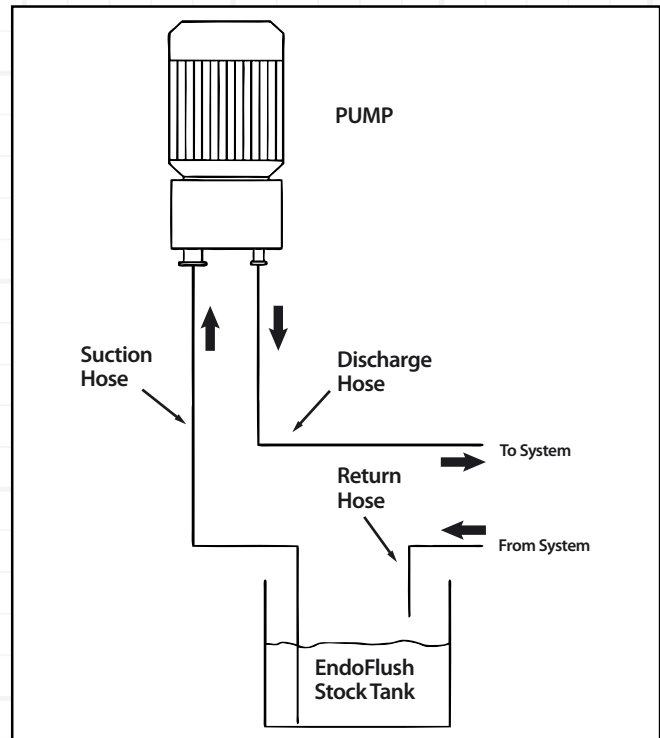

FIG 1. FLUSHING PUMP ARRANGEMENT

Note; The above procedures are to be considered as general guidance only, due to the variations in system design. If in doubt check with the equipment manufacturer or Advanced Engineering prior to use. Advanced Engineering Ltd and its Distributors assume no liability for the misuse or misapplication of this product.